

EXHIBIT B-11
SUPPLEMENTAL CONDOMINIUM PLAN
OF
WYNDHAM PLANTATION
CONDOMINIUM

WILLIAMSBURG, VIRGINIA
SCALE: 1"=10' FEBRUARY 1, 2002

JOHN E. SIRINE AND ASSOCIATES, LTD.
SURVEYORS • ENGINEERS • PLANNERS
VIRGINIA BEACH, VIRGINIA
(757) 486-4910

NOTES:

1. BUILDING DIMENSIONS SHOWN HEREON ARE INTERIOR DIMENSIONS. THESE DIMENSIONS ARE IN FEET AND WERE TAKEN FROM PLANS SUPPLIED ENTITLED "WYNDHAM PLANTATION AT WILLIAMSBURG, FLOOR PLANS" BY PROGRESSIVE DESIGNS DATED 11/19/98.
2. INTERIOR UNIT CONFIGURATIONS AND PARTITIONS AS DEPICTED HEREON ARE FOR THE PURPOSE OF ILLUSTRATION ONLY AND MAY NOT REPRESENT THE INTERIOR OF A UNIT AS ACTUALLY CONSTRUCTED.

SECOND FLOOR - BUILDING 11

SCALE: 1"=10'

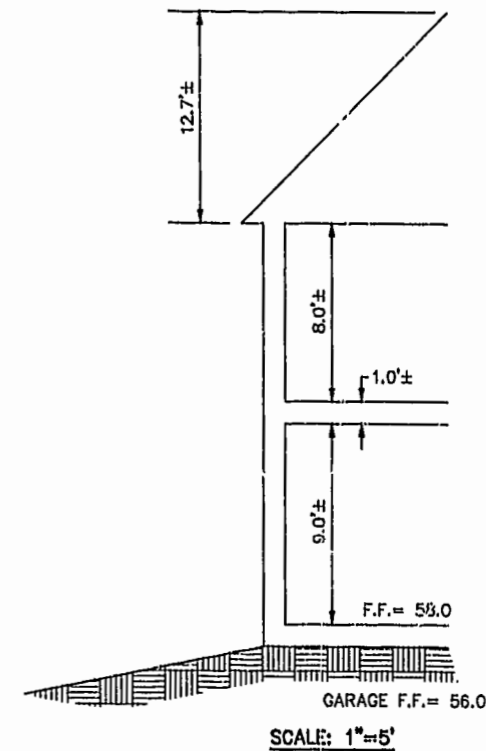
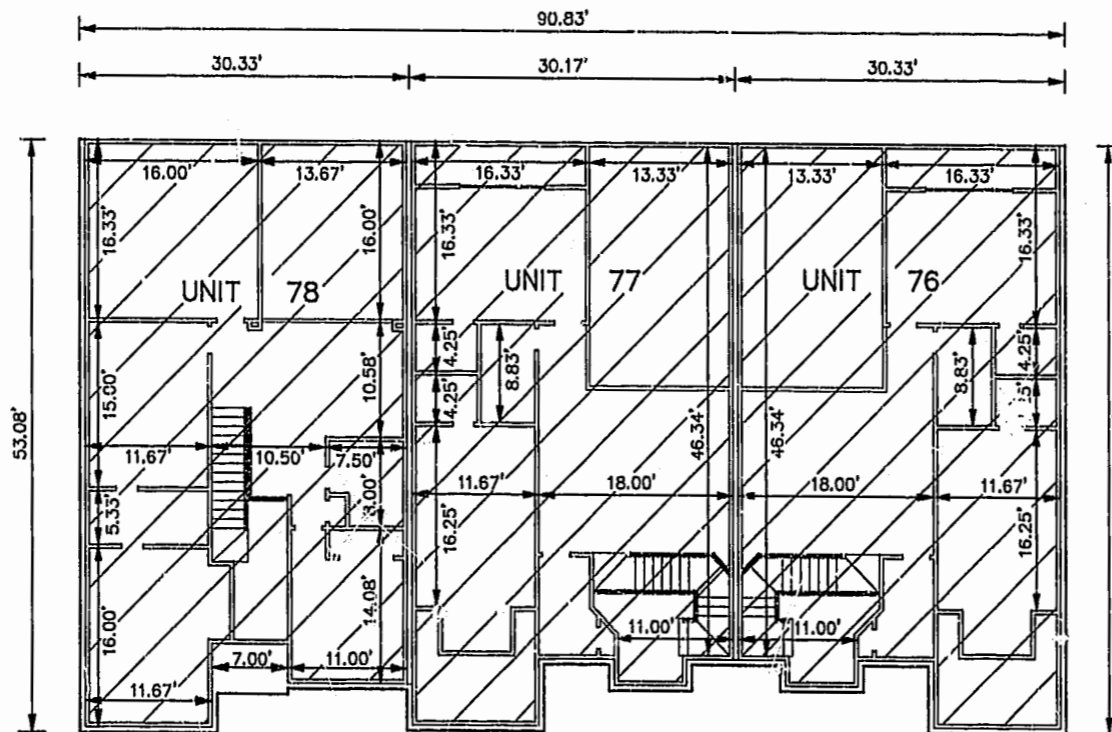

UNIT AREA

THE UNDERSIGNED CERTIFIES THAT THESE PLANS ARE ACCURATE AND COMPLY WITH THE PROVISIONS OF CODE OF VIRGINIA, SECTION 55-79.58.B AND THAT ALL UNITS OR PORTIONS THEREOF DEPICTED HEREON AND ALL COMMON ELEMENTS HAVE BEEN SUBSTANTIALLY COMPLETED.

PHASE	UNIT No.	UNIT ADDRESS	UNIT AREA
12	78	292 ZELKOVA ROAD	1,997 S.F.
12	77	288 ZELKOVA ROAD	1,957 S.F.
12	76	284 ZELKOVA ROAD	2,101 S.F.

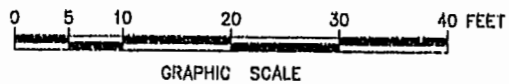

City of Williamsburg & County of James City
Circuit Court: This PLAT was recorded on
25 February 2002
at 3:23 P.M. P.B. 25 PG. 25-32
DOCUMENT # 020357
BETSY B. WOOLRIDGE, CLERK
Betsy B. Woolridge, Rep. Clerk

SIGNED: Jeffrey D. Williams
JEFFREY D. WILLIAMS, L.S.

