

SECTION A-A

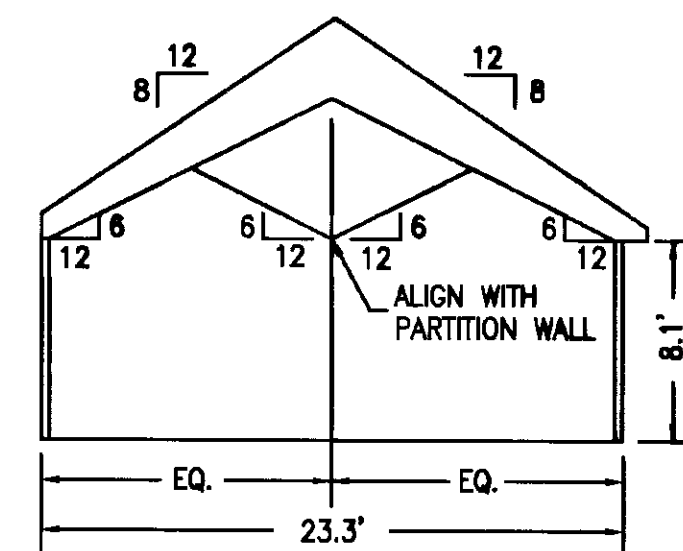

SECTION B-B

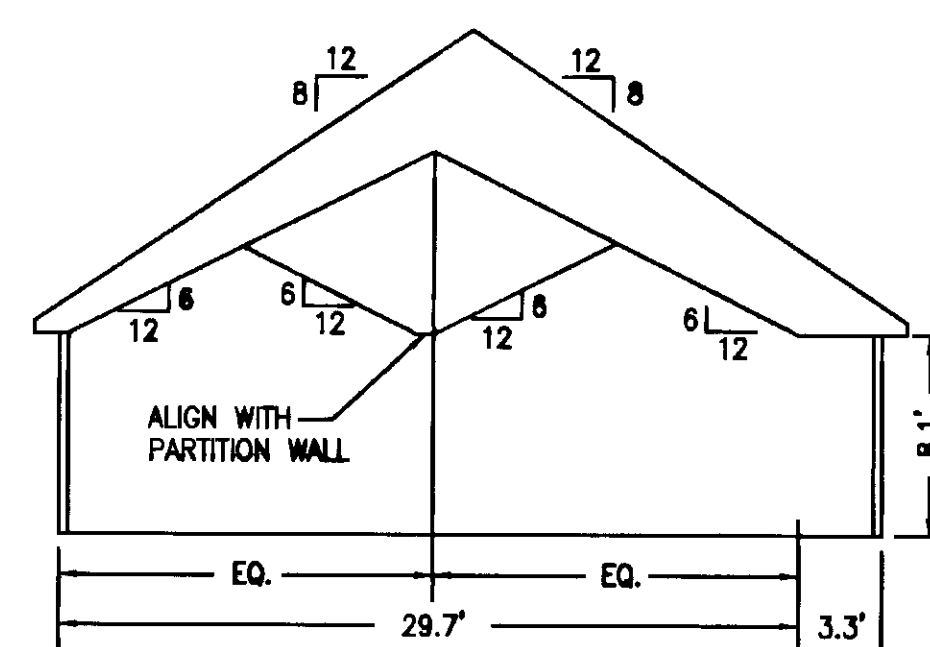

SECTION C-C

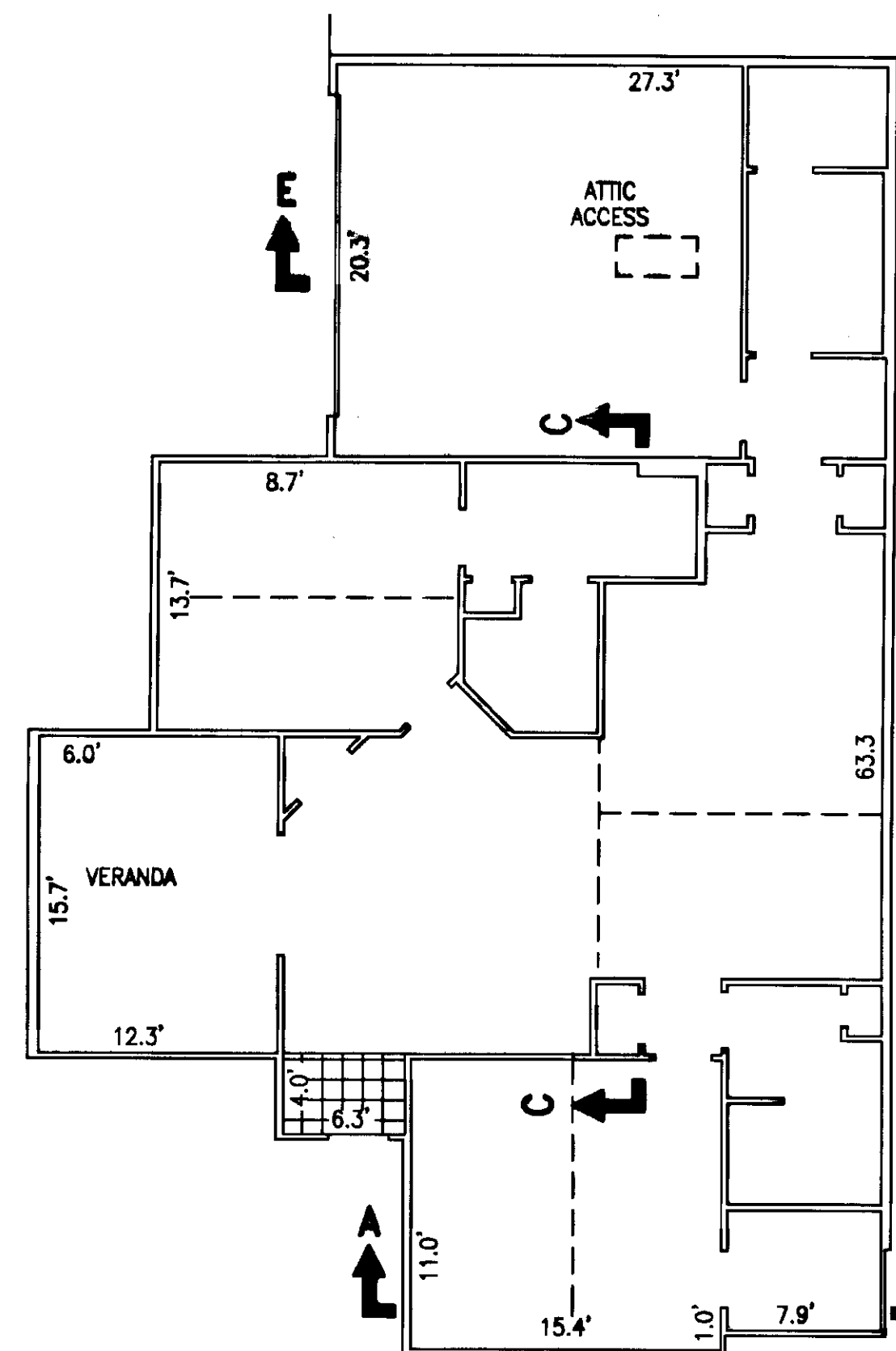

BUILDING 14-A  
ABBAY  
FLOOR PLAN

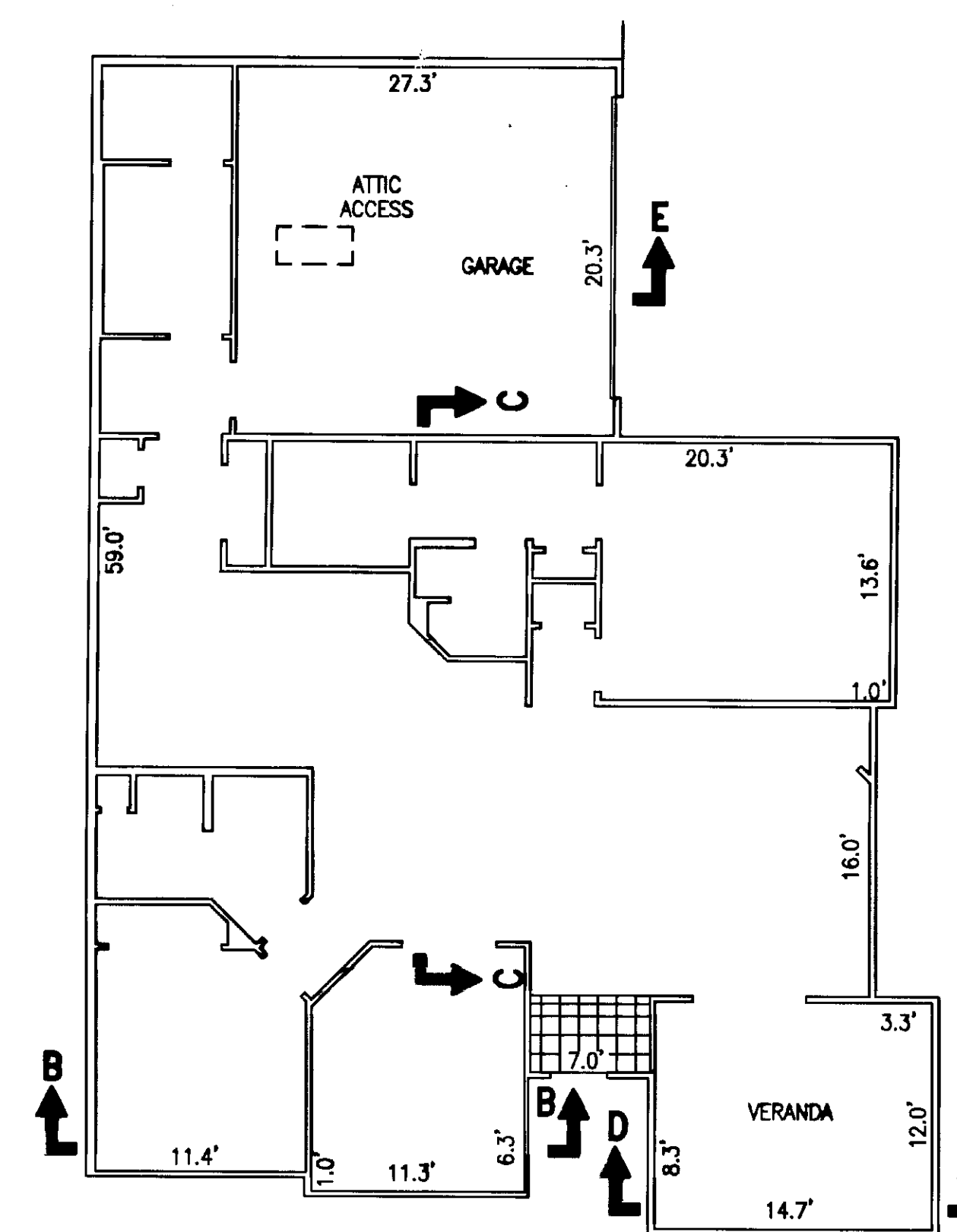

BUILDING 14-B, 14-C & 14-D  
CANTERBURY  
FLOOR PLAN

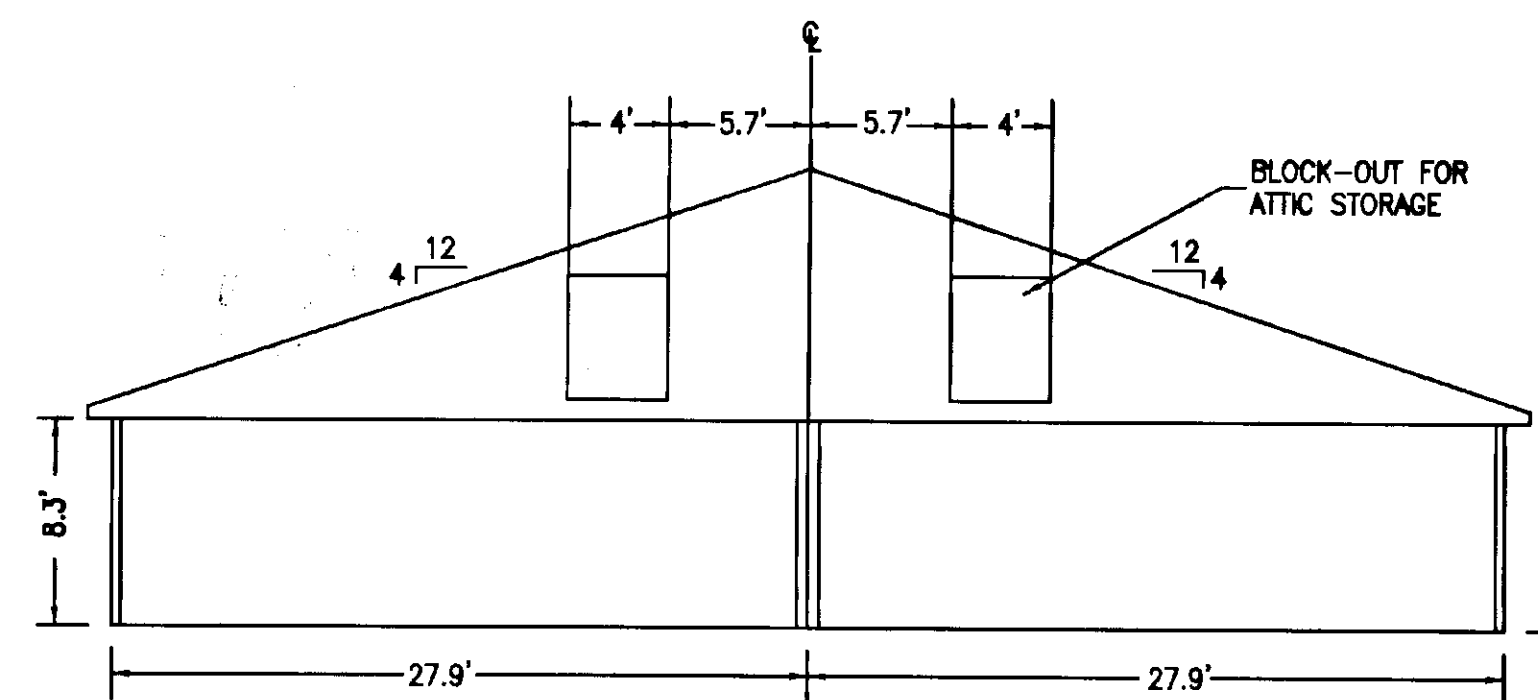

SECTION E-E

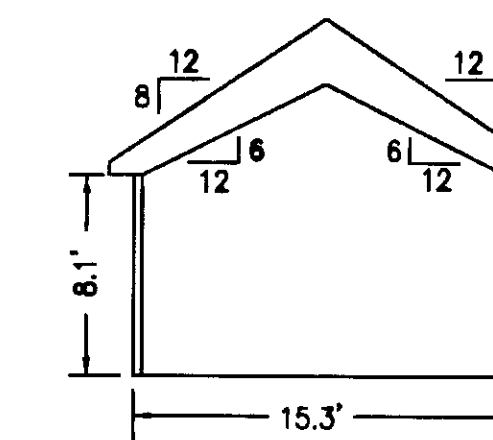

SECTION D-D

I CERTIFY THAT THESE PLANS ARE ACCURATE AND COMPLIES WITH THE PROVISIONS OF SECTION 55-79.58(B) OF THE CODE OF VIRGINIA OF 1950 AS AMENDED AND ALL UNITS SHOWN HEREON HAVE BEEN SUBSTANTIALLY COMPLETED.

NAME: George V. Huggette, Jr. REGISTRATION NO.: 1430

DATE: FEBRUARY 28, 2013

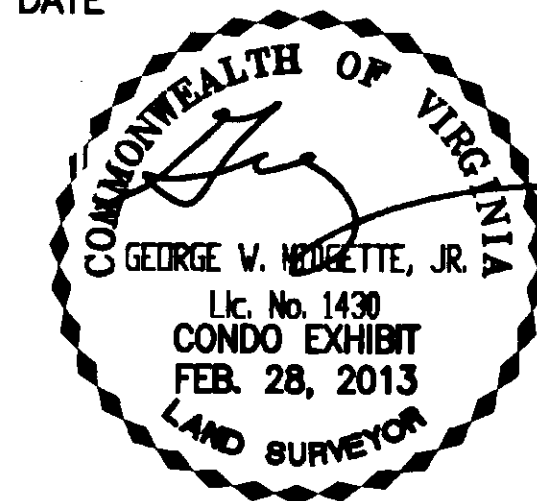

STATE OF VIRGINIA  
JAMES CITY COUNTY

IN THE CLERK'S OFFICE OF THE CIRCUIT COURT FOR JAMES CITY COUNTY, VIRGINIA. THIS MAP WAS PRESENTED AND ADMITTED TO RECORD AS THE LAW DIRECTS THIS 14<sup>TH</sup> DAY OF March, 2013 AT 8:48 AM.

INSTRUMENT # 130007241

TESTES: \_\_\_\_\_

TESTES: Indrick Whalrus deputy clerk

<p><b>EXHIBIT "D"</b> PLANS OF <b>VILLAS AT FIVE FORKS</b> A CONDOMINIUM PHASE 18 JAMES CITY COUNTY, VIRGINIA</p>		<p><b>ART-RAY CORP.</b>  200 LUMMIS ROAD SUFFOLK, VIRGINIA 23434 Office: 757.539.8822 Fax: 757.539.6769</p>	
<p>DOC.#120008351</p>		<p><b>3</b> SHEET: 3 of 3</p>	