

100017139

CURVE TABLE						
CURVE #	DELTA	RADIUS	LENGTH	TANGENT	CHORD	CHORD BEARING
C1	50°43'59"	25.00'	22.14'	11.85'	21.42'	N32°52'40"E
C2	1°03'16"	520.00'	9.57'	4.79'	9.57'	N58°46'17"E
C3	1°04'06"	520.00'	9.70'	4.85'	9.70'	N78°50'59"E
C4	11°51'59"	559.00'	115.77'	58.10'	115.57'	S65°13'55"W
C5	1°59'11"	559.00'	19.38'	9.69'	19.38'	S72°09'30"W
C6	1°07'59"	559.00'	11.05'	5.53'	11.05'	S73°43'05"W
C7	65°25'36"	559.00'	638.33'	359.06'	604.21'	S73°00'07"E
C8	11°27'11"	569.00'	113.74'	57.06'	113.55'	N65°01'31"E
C9	2°48'12"	569.00'	27.84'	13.92'	27.84'	S72°09'12"W
C10	66°09'23"	569.00'	656.99'	370.62'	621.10'	N73°22'00"W

LINE TABLE		
LINE	BEARING	LENGTH
L1	N58°14'39"E	5.98'
L2	N30°42'05"W	4.00'
L3	S26°39'38"W	8.11'
L4	S71°39'38"W	7.75'
L5	N63°20'22"W	8.34'
L6	N18°20'22"W	16.66'
L7	S71°39'38"W	10.00'

LINE TABLE		
LINE	BEARING	LENGTH
L8	S18°20'22"E	17.31'
L9	N30°42'05"W	10.00'
L10	N26°39'38"E	8.18'
L11	N71°39'38"E	16.03'
L12	S63°20'22"E	8.52'
L13	N30°42'05"W	11.00'

REFERENCES:
 D.B. 598, PG. 279, D.B. 262, PG. 356, D.B. 232, PG. 34,
 D.B. 48, PG. 1, 2, & PG. 5, P.B. 56, PG. 72.

Large/Small Plat(s) Recorded
 herewith as # 100017139

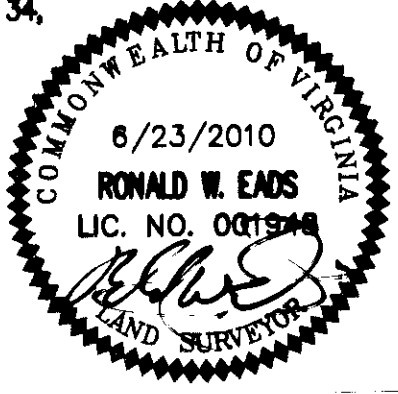
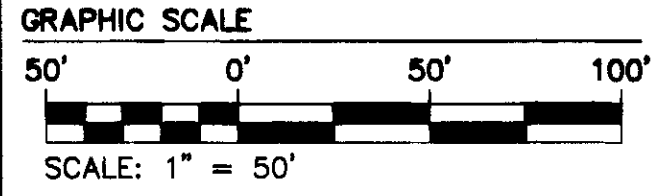

City of Williamsburg & County of James City
 Circuit Court: This PLAT was recorded on
 8-17-2010
 at 3:22 AM/PM. PG. 1
 DOCUMENT # 100017139
 BETSY B. WOOLRIDGE, CLERK
Betsy B. Woolridge Clerk

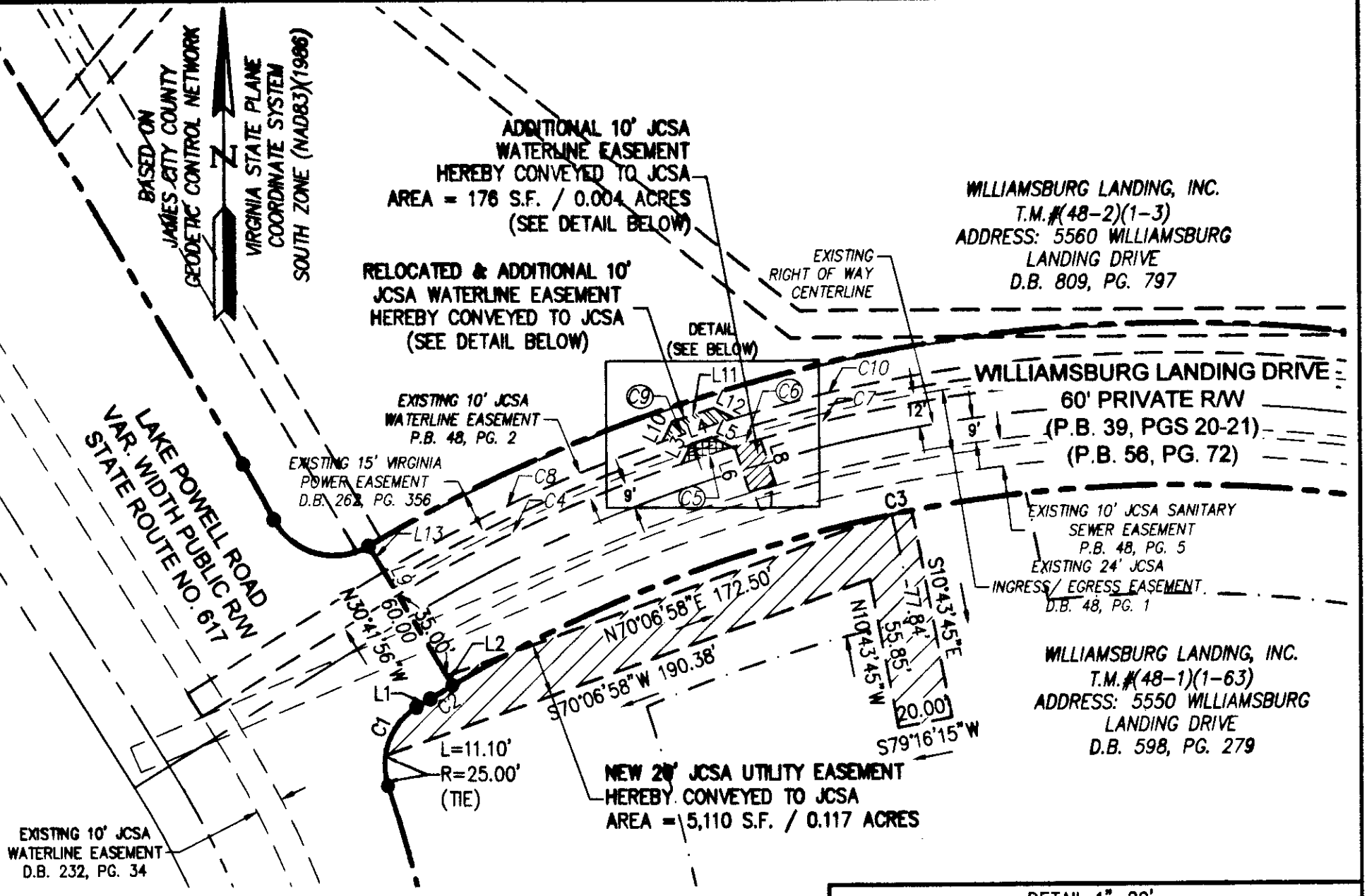

PORTIONS OF EXISTING
 EASEMENT LINES C5, C6 & C9
 ARE HEREBY EXTINGUISHED.

LEGEND & AREA TABULATION

	ORIGINAL JCSA WATERLINE EASEMENT	AREA = 362 S.F. / 0.008 AC.
	RELOCATED JCSA WATERLINE EASEMENT	AREA = 123 S.F. / 0.003 AC.
	EXTINGUISHED JCSA WATERLINE EASEMENT	AREA = 78 S.F. / 0.002 AC.
	ADDITIONAL JCSA WATERLINE EASEMENT	AREA = 176 S.F. / 0.004 AC.

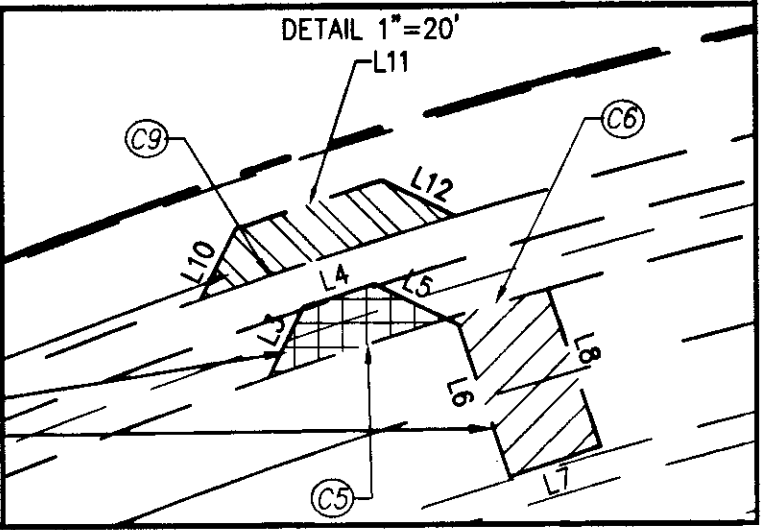

WILLIAMSBURG LANDING, INC.
 T.M. # (48-2)(1-3)
 ADDRESS: 5560 WILLIAMSBURG
 LANDING DRIVE
 D.B. 809, PG. 797

WILLIAMSBURG LANDING, INC.
 T.M. # (48-1)(1-63)
 ADDRESS: 5550 WILLIAMSBURG
 LANDING DRIVE
 D.B. 598, PG. 279

Rev.	Date	Description	Revised by

NES
 CONSULTING ENGINEERS
 5246 Old Towne Road, Suite 1
 Williamsburg, Virginia 23188
 Phone: (757) 253-0040
 Fax: (757) 220-8994
 www.nesva.com
 Hampton Roads | Central Virginia | Middle Peninsula

PLAT OF EASEMENT
 FROM: WILLIAMSBURG LANDING, INC.
 TO: JAMES CITY SERVICE AUTHORITY
 JAMESTOWN DISTRICT JAMES CITY COUNTY VIRGINIA

Project Contacts:	RWE
Project Number:	8162-06
Scale:	1"=50'
Date:	8/23/2010
Sheet Number:	1 OF 1