

#050019594









CE- COMMON ELEMENTS

COMMON ELEMENTS INCLUDE ALL PORTIONS OF THE CONDOMINIUM OTHER THAN THE UNITS SHOWN AND DESIGNATED HEREON AND DEFINED IN THE CONDOMINIUM DOCUMENTS AND THE LIMITED COMMON ELEMENTS. EXAMPLES OF COMMON ELEMENTS ARE: PARKING, PAVED AREAS, THE GROUNDS (WHETHER OR NOT LANDSCAPED), ALL PORTIONS OF THE BUILDINGS NOT A PART OF THE UNIT NOR DEFINED AS LIMITED COMMON ELEMENTS, AND ALL CONDUITS, INSTALLATIONS, WIRES, PIPES, EQUIPMENT, ETC. WHICH SERVE OTHER COMMON ELEMENTS OR WHICH SERVE MORE THAN ONE UNIT. REFERENCE IS HEREBY MADE TO THE DECLARATION OF CONDOMINIUM FOR ADDITIONAL DEFINITIONS, REGULATIONS, AND BUILDING RESTRICTIONS IMPOSED BY THE DEVELOPER AND/OR HIS ASSIGNS.

LCF- LIMITED COMMON ELEMENTS

EXCEPT AS MAY BE OTHERWISE EXPRESSLY PROVIDED, LIMITED COMMON ELEMENTS INCLUDE ANY HEATING AND AIR CONDITIONING EQUIPMENT DESIGNED TO SERVE A SINGLE UNIT AS DEFINED IN THE CONDOMINIUM DOCUMENT, NOT WITHSTANDING THE FACT THE APPARATUS AND/OR EQUIPMENT LIES WITHIN A UNIT AND OR COMMON ELEMENT. REFERENCE IS HEREBY MADE TO THE DECLARATION OF CONDOMINIUM FOR ADDITIONAL DEFINITIONS, REGULATIONS, AND BUILDING RESTRICTIONS IMPOSED BY THE DEVELOPER AND/OR HIS ASSIGNS.

LEGEND

- UNITS 
- COMMON ELEMENT 
- LIMITED COMMON ELEMENT 
- WATER VALVE 
- SEWER CLEAN OUT 
- FIRE HYDRANT 
- LIGHT POLE 
- IRON ROD SET 

PARCEL 'A' BLOCK 5
NEW TOWN
NEW TOWN ASSOCIATES LLC
TAX PARCEL #(38-4)(24-6)
INSTR. #030010942
INSTR. #040009441

5' UTILITY EASEMENT
INSTR. #040009441
INSTR. #030010942

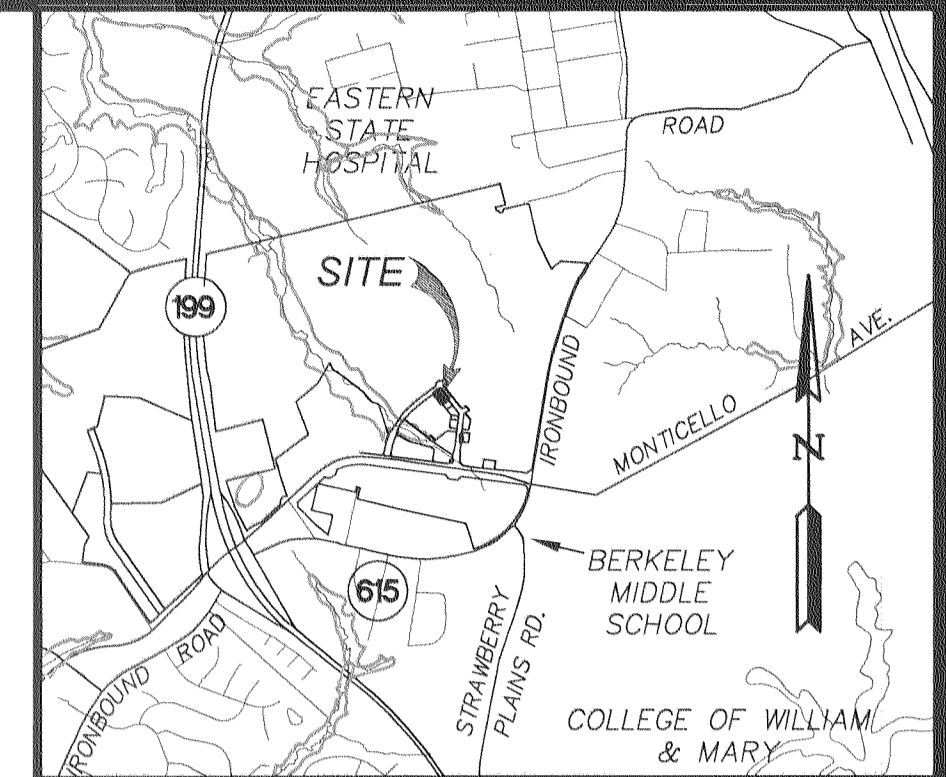
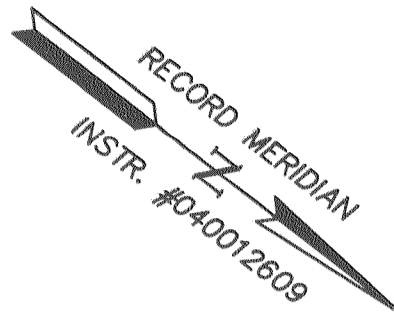

VICINITY MAP
SCALE: 1"=2000'±

GENERAL NOTES

1. THE SITE IS CURRENTLY ZONED MU-MIXED USE WITH PROFFERS. FOR PROFFERS REFERENCE JCC CASE NO. Z-03-01 AND MP-02-97 APPROVED BY THE BOARD OF SUPERVISORS ON DECEMBER 11, 2001.
2. THIS PROPERTY LIES IN ZONE X (AREAS DETERMINED TO BE OUTSIDE THE 500 YEAR FLOOD PLAIN) PER F.I.R.M. # 510201 0035 B DATED 2/6/91.
3. OWNER/DEVELOPER: SIGNATURE VENTURES, L.L.C. AND NHG NEWTOWN, L.L.C.
460 McLAWS CIRCLE, SUITE 120
WILLIAMSBURG, VIRGINIA 23185-5671

ARCHITECTS: COMMONWEALTH ARCHITECTS
101 SHOCKOE SLIP, THIRD FLOOR
RICHMOND, VA 23219
CONTACT: RICHARD FORD
PHONE NO.: (804) 648-5040

4. SITE ADDRESS: PARCEL E-5121 CENTER STREET
5. TAX PARCEL ID NO.: (38-2)(24-1)
6. LEGAL DESCRIPTION: BLOCK 5 PARCEL "E"
7. PROPERTY REF.: INSTRUMENT #040024036 (DEED)
INSTRUMENT #040012609 (PLAT)
8. A WAIVER TO SEC. 24-527(A) OF THE JAMES CITY COUNTY CODE, SETBACK REQUIREMENTS FROM A PLANNED OR EXISTING PUBLIC ROAD RIGHT OF WAY, WAS GRANTED BY THE JAMES CITY COUNTY PLANNING COMMISSION ON APRIL 5, 2004 PROVIDED PROPOSALS ARE IN ACCORDANCE WITH THE NEW TOWN DESIGN GUIDELINES.
9. A WAIVER TO SEC. 24-55 OF THE JAMES CITY COUNTY CODE, LOCATION OF OFF-SITE PARKING AND MINIMUM OFF STREET PARKING REQUIREMENTS WAS GRANTED BY THE JAMES CITY COUNTY PLANNING COMMISSION ON MARCH 1, 2004 PROVIDED PROPOSALS ARE IN ACCORDANCE WITH THE "NEW TOWN TOWN CENTER PARKING OVERVIEW" LETTER JANUARY 2004.
10. THIS PLAT IS BASED ON AN ACTUAL FIELD SURVEY.

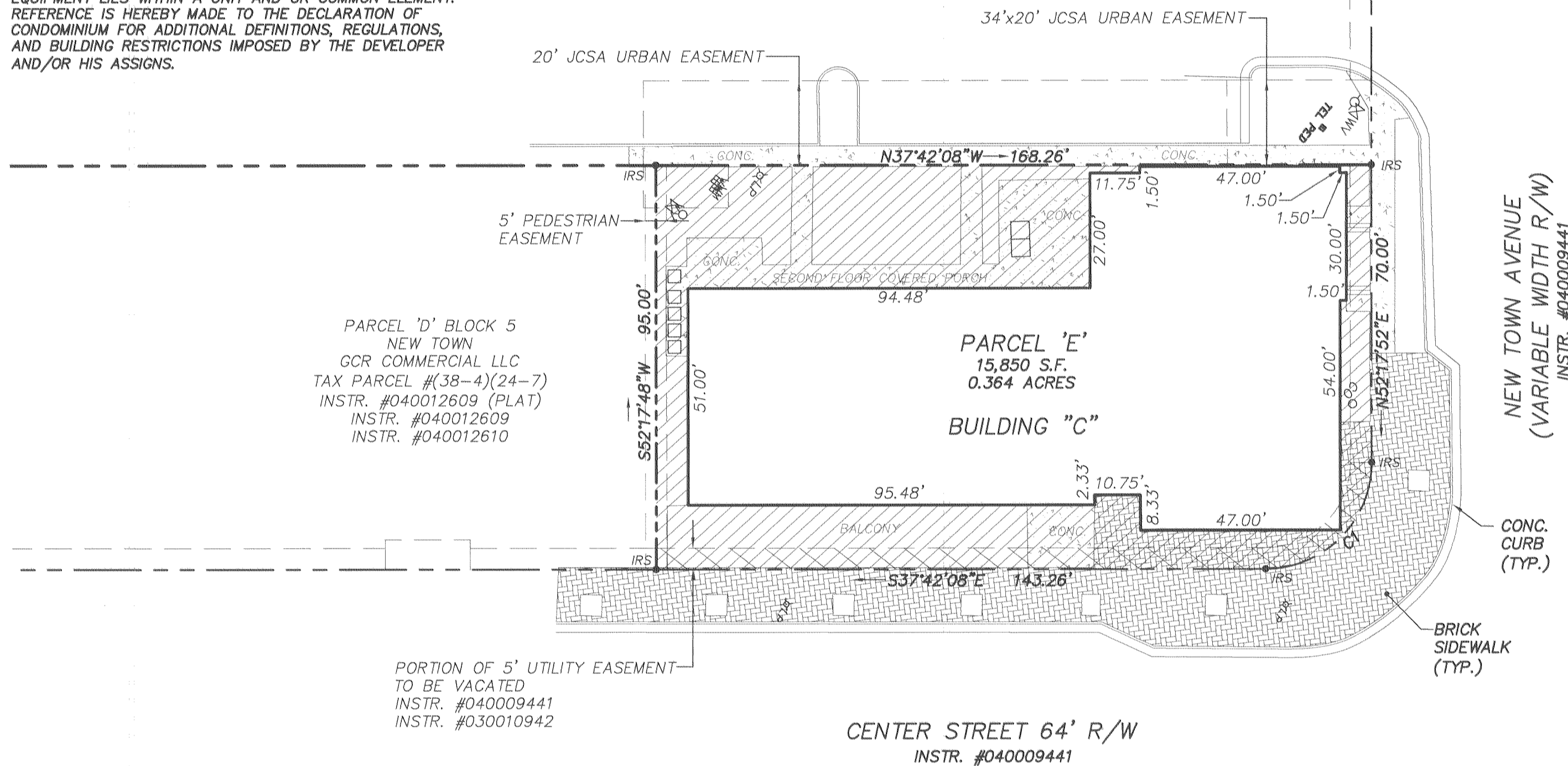

PARCEL 'D' BLOCK 5
NEW TOWN
GCR COMMERCIAL LLC
TAX PARCEL #(38-4)(24-7)
INSTR. #040012609 (PLAT)
INSTR. #040012609
INSTR. #040012610

PORTION OF 5' UTILITY EASEMENT
TO BE VACATED
INSTR. #040009441
INSTR. #030010942

CENTER STREET 64' R/W
INSTR. #040009441

CURVE TABLE						
CURVE	DELTA	RADIUS	ARC	TANGENT	CHORD	CHORD BRG.
C1	90°00'00"	25.00	39.27	25.00	35.36	S82°42'08"E

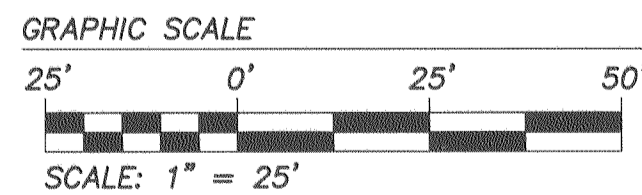

SURVEYOR'S CERTIFICATE

I HEREBY CERTIFY THAT, TO THE BEST OF KNOWLEDGE AND BELIEF, THIS PLAT IS ACCURATE AND COMPLIES WITH THE PROVISIONS OF VA. CODE ANN. SUBSECTIONS 55-79.58 A, B AND F AND THAT ALL UNITS OR PORTIONS THEREOF HAVE BEEN SUBSTANTIALLY COMPLETED.

Robert D. Mann
ROBERT D. MANN, L.S. #2509
DATE: 8/18/05

City of Williamsburg & County of James City
Circuit Court: This PLAT was recorded on
23 August 2005
at 9:42 AM/PM PB PG
DOCUMENT # 050019594
BETSY B. WOOLRIDGE, CLERK
Betsy B. Woolridge

EXHIBIT B

PLAT FOR CONDOMINIUM

5121 CENTER STREET, A CONDOMINIUM

OWNER/DEVELOPER: SIGNATURE VENTURES, L.L.C.
AND NHG NEWTOWN, L.L.C.

BERKELEY DISTRICT JAMES CITY COUNTY VIRGINIA

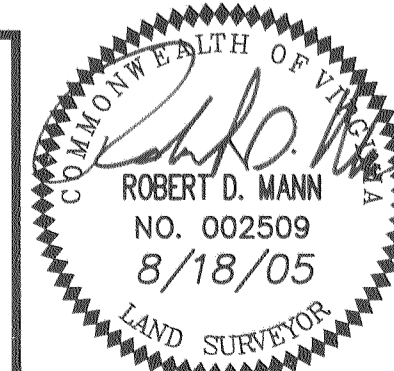

No.	DATE	REVISION / COMMENT / NOTE	REVISED BY	REVIEWED BY
2	8/18/05	ADDITIONAL LOCATION-FINAL PLAT	RD	RD
1	1/13/05	REVISED LEGEND	RD	RD

Designed	Drawn
Scale	Date
RD	EAW
1"=25'	1/10/05
Project No. 6632E10-3C	
Drawing No. 1 OF 1	

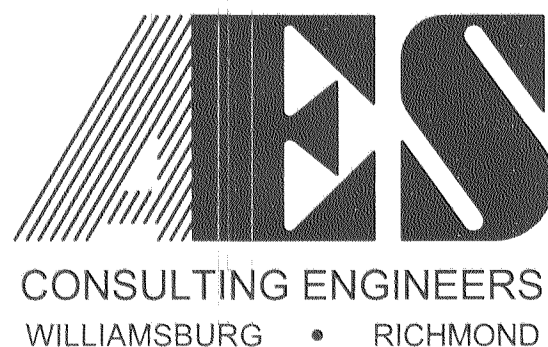

5248 Olde Towne Road, Suite 1
Williamsburg, Virginia 23188
(757) 253-0040
Fax (757) 220-8994