

050004203

File: N:\Projects\2004\04-745\DWG\04-745, Plotted: 1-10-05 at 11:12, By: KEN

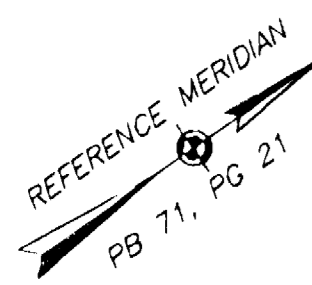
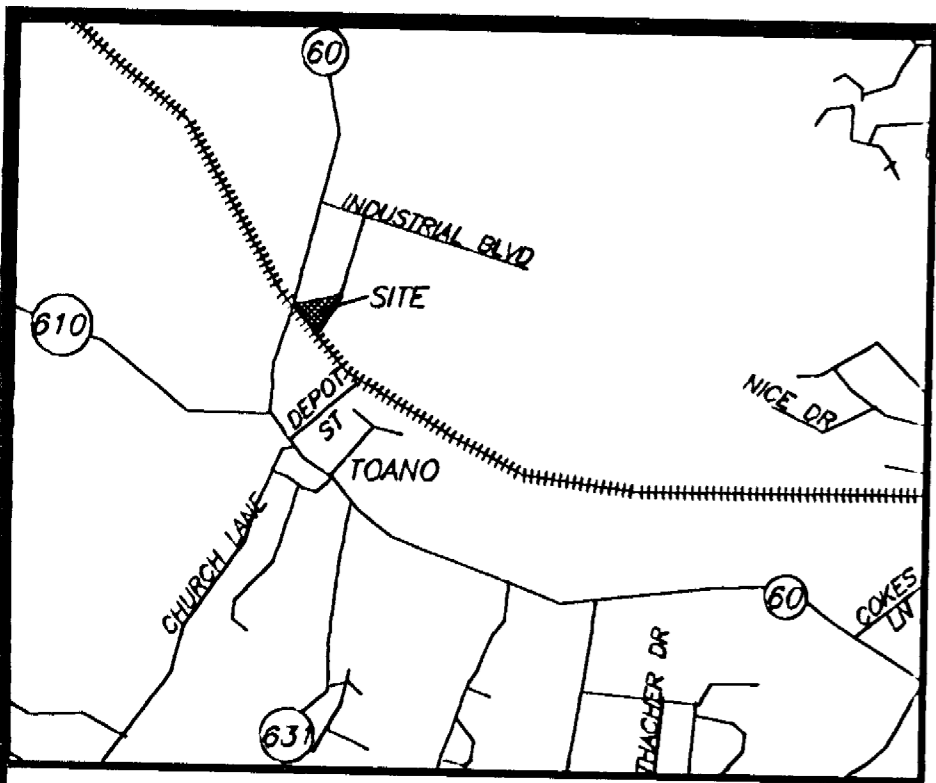

R=2821.58'  
L=336.31'  
T=168.36'  
Δ=06°49'45"  
CD=N37°54'57"W  
CL=336.11'

City of Williamsburg & County of James City  
Circuit Court  
This PLAT was recorded on  
at 10:21 AM/PM PB  
DOCUMENT # 050004203  
PG  
BETSY B. WOOLRIDGE, CLERK  
Clerk

STATE OF VIRGINIA  
JAMES CITY COUNTY  
IN THE CLERK'S OFFICE OF THE CIRCUIT COURT FOR THE JAMES CITY COUNTY, VIRGINIA, THIS MAP WAS  
PRESENTED AND ADMITTED TO RECORD AS THE LAW DIRECTS THIS 1st DAY OF June  
2005 AT 10:21 AM/PM  
INSTRUMENT # 050004203  
TESTES: Betsy B. Woolridge  
CLERK  
TESTES: Claudia J. Woolridge  
DEPUTY CLERK

STATE ROUTE NO. 60  
160' R/W

I HEREBY CERTIFY THAT THIS PLAT IS ACCURATE AND  
COMPLIES WITH THE CODE OF VIRGINIA OF 1950, AS  
AMENDED 55-79.58, AND I FURTHER CERTIFY THAT ALL  
UNITS OR PORTIONS THEREOF DEPICTED ON SAID PLANS,  
PURSUANT TO THE CODE OF VIRGINIA 55-79.58B, HAVE  
BEEN SUBSTANTIALLY COMPLETED.

SIGNED: Gary C. Thomas  
GARY C. THOMAS, L.S.

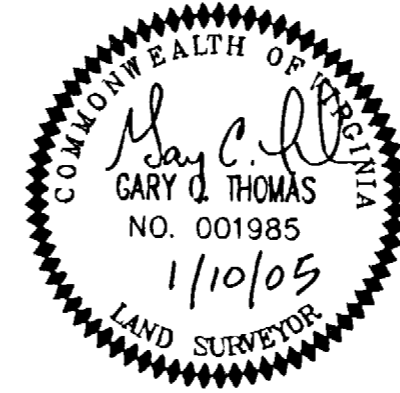

PLAT OF  
**HANKINS BUSINESS CENTER**  
A CONDOMINIUM  
JSRS ASSOCIATES L.L.C., A VIRGINIA LIMITED LIABILITY COMPANY  
JAMES CITY COUNTY, VIRGINIA

DATE: 11/29/04	SHEET 1 OF 2	SCALE: 1" = 25'
PROJECT NO: 04-745	DRAWN BY: BSH	

**THOMAS LAND SURVEYING, P.C.**  
SURVEYING-GPS-MAPPING  
11830-A CANON BOULEVARD  
NEWPORT NEWS, VIRGINIA 23606  
(757) 873-2770

THIS PLAT SHALL BE PART OF THE DOCUMENTATION FOR  
THE DECLARATION OF CONDOMINIUM DATED THE \_\_\_\_\_  
DAY OF \_\_\_\_\_, 2005, RECORDED IN THE CLERK'S  
OFFICE OF THE CIRCUIT COURT OF JAMES CITY COUNTY,  
VIRGINIA INSTRUMENT # \_\_\_\_\_

PLAT OF HANKINS BUSINESS CENTER A CONDOMINIUM FOR  
JSRS ASSOCIATES, L.L.C., A VIRGINIA LIMITED LIABILITY  
COMPANY.

THE PROPERTY CONTAINED WITHIN THE LIMITS OF THIS  
CONDOMINIUM WAS CONVEYED TO HANKINS BUSINESS  
CENTER L.L.C. RECORDED AS INSTRUMENT #04015441,  
DATED 6/17/04, IN THE CIRCUIT COURT OF JAMES CITY  
COUNTY, VIRGINIA.

TOTAL AREA ENCOMPASSED = 1.7502 ACRE.

ALL PARKING AREAS AND DRIVE AISLES ARE PRIVATE AND  
ARE COMMON ELEMENTS.

ALL AREA SHOWN HEREON THAT ARE NOT CONSIDERED A  
CONDOMINIUM UNIT SHALL BE COMMON ELEMENT.

VERTICAL BOUNDARIES ARE THE INTERIOR FACES OF THE  
PLYWOOD OR OTHER ROOF SHEATHING.

HORIZONTAL BOUNDARIES ARE THE UNFINISHED SURFACES  
OF PERIMETER WALLS AND THE CENTER OF EXISTING  
WALLS BETWEEN EACH UNIT.

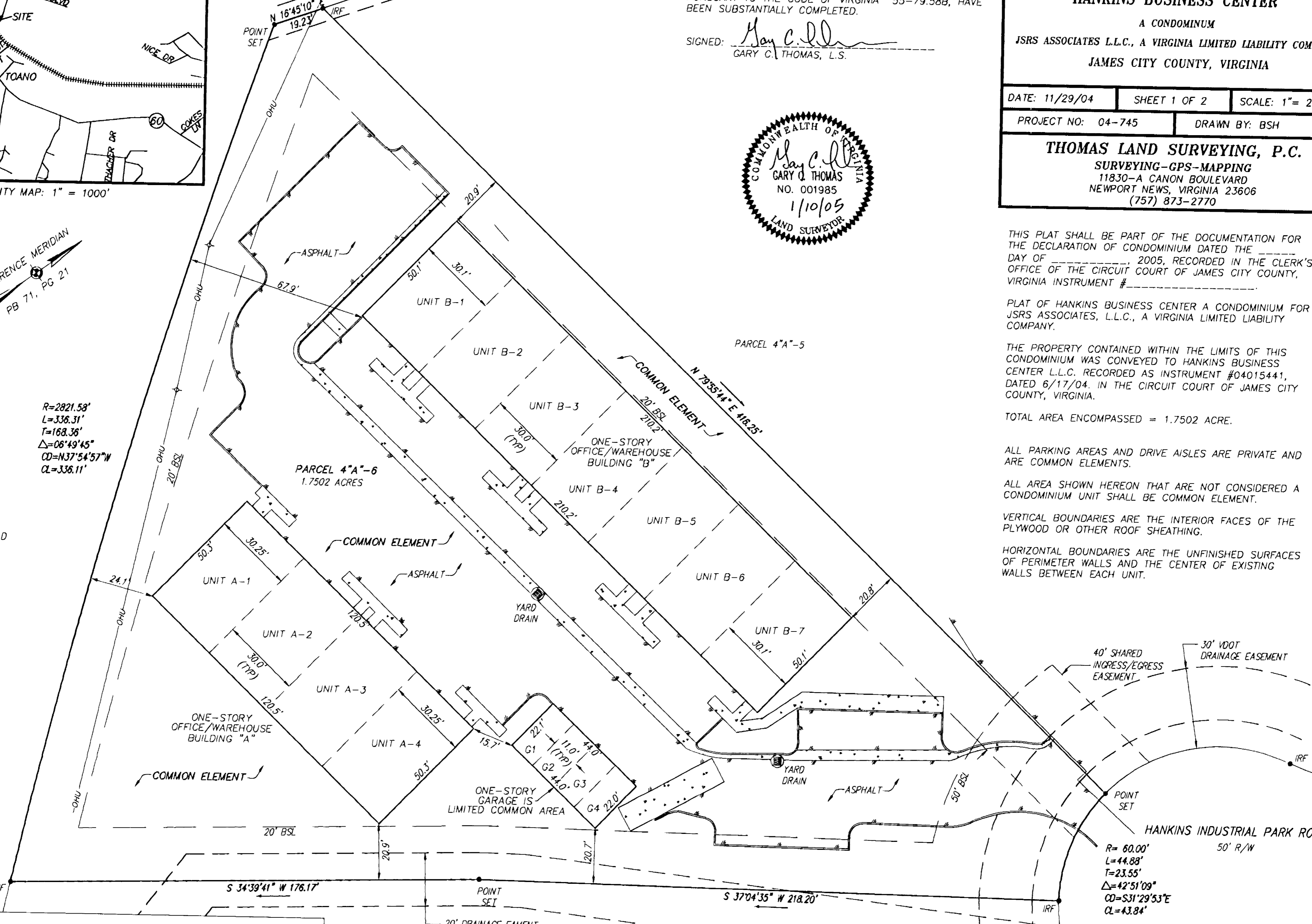

R= 60.00'  
L=44.88'  
T=23.55'  
Δ=42°51'09"  
CD=S31°29'53"E  
CL=43.84'

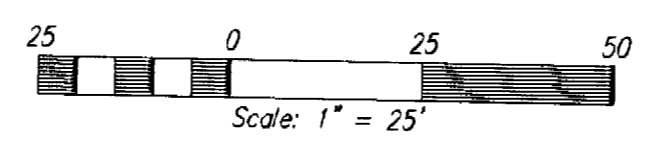

COMMON ELEMENT SHOWN HEREON ARE APPROXIMATE AND  
SHALL BE CONSISTENT WITH DECLARATION OF CONDOMINIUM.

2 Larger Small Plat(s) Recorded  
herewith as # 050004203

I:\Projects\2004\04-745\DWG\04-745, Plotted: 1-10-05 at 11:12, By: KEN #050004203

**BUILDING A**  
UNITS A-1 THRU A-4

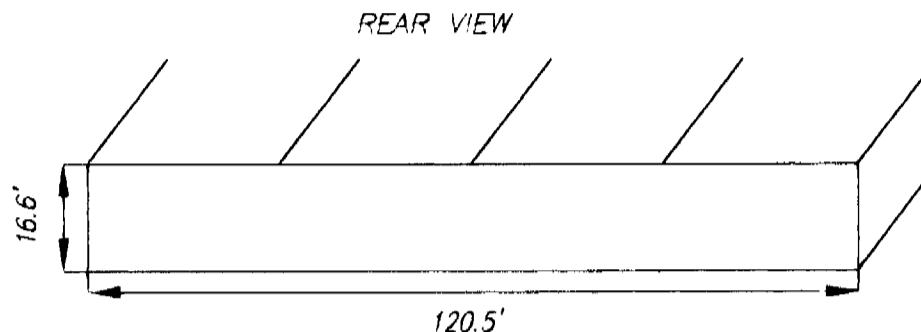
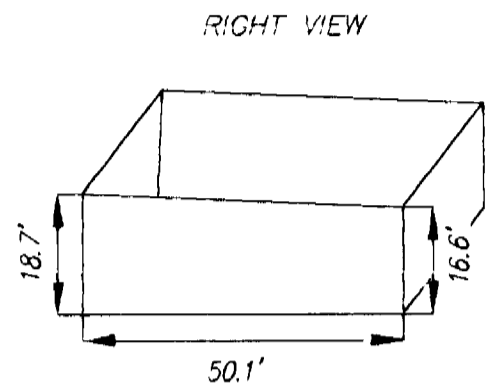
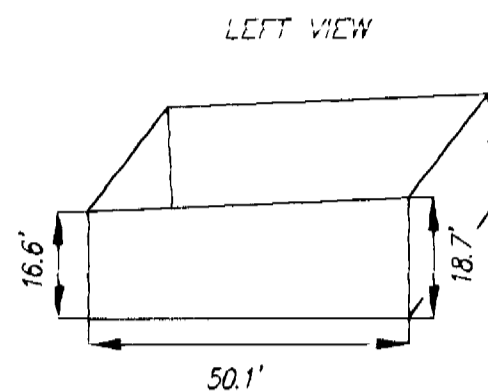
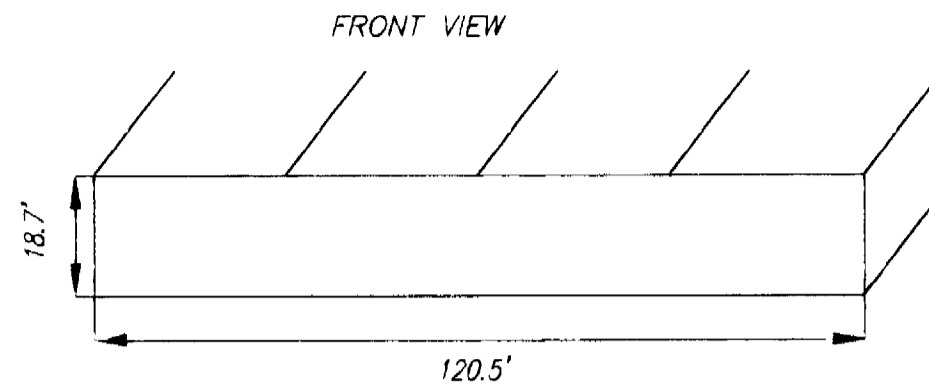
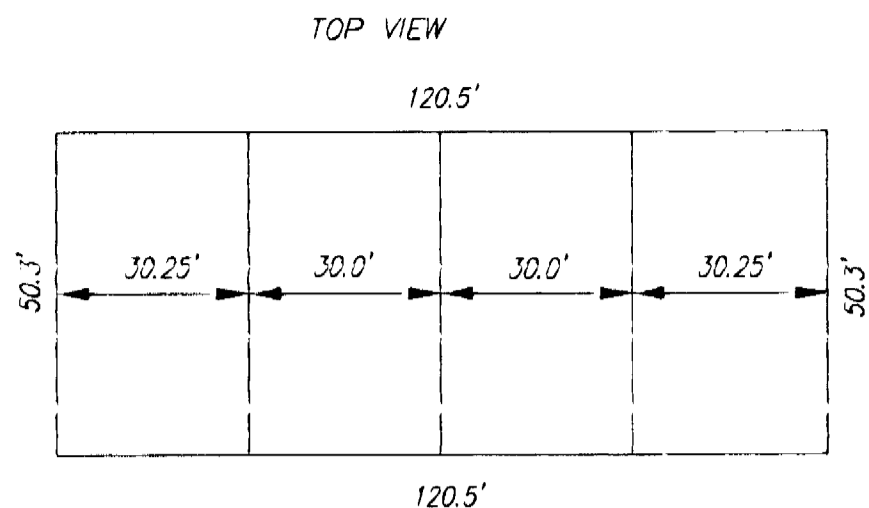

**BUILDING B**  
UNITS B-1 THRU B-7

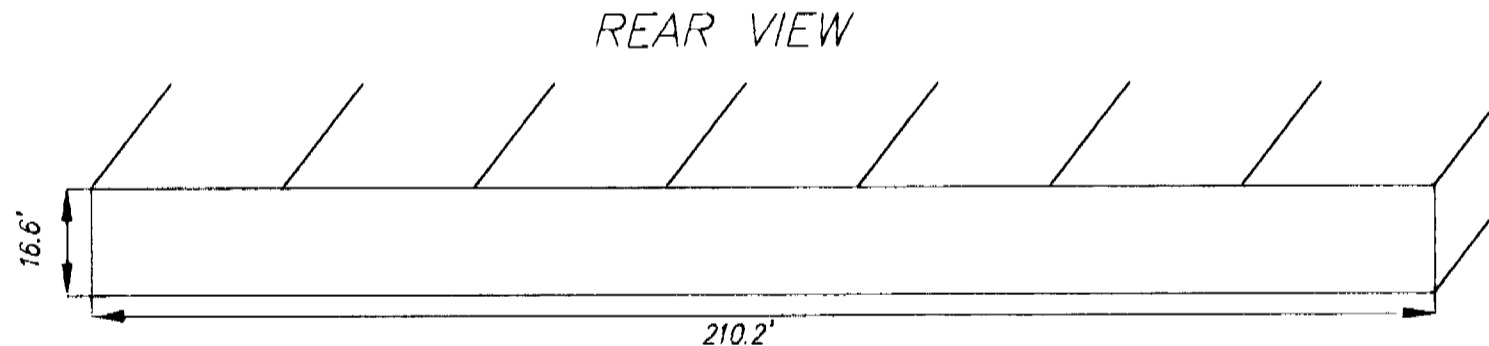
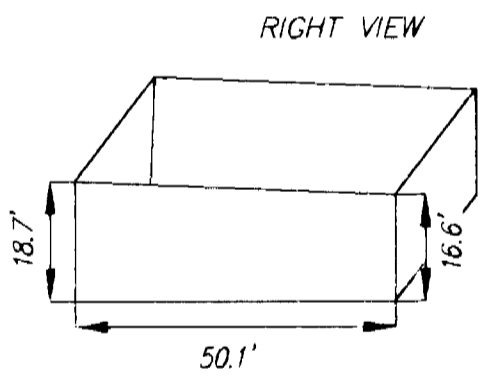
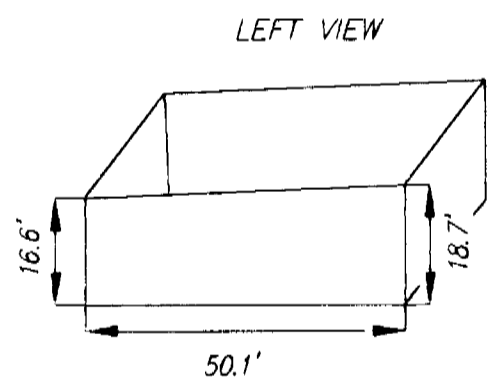
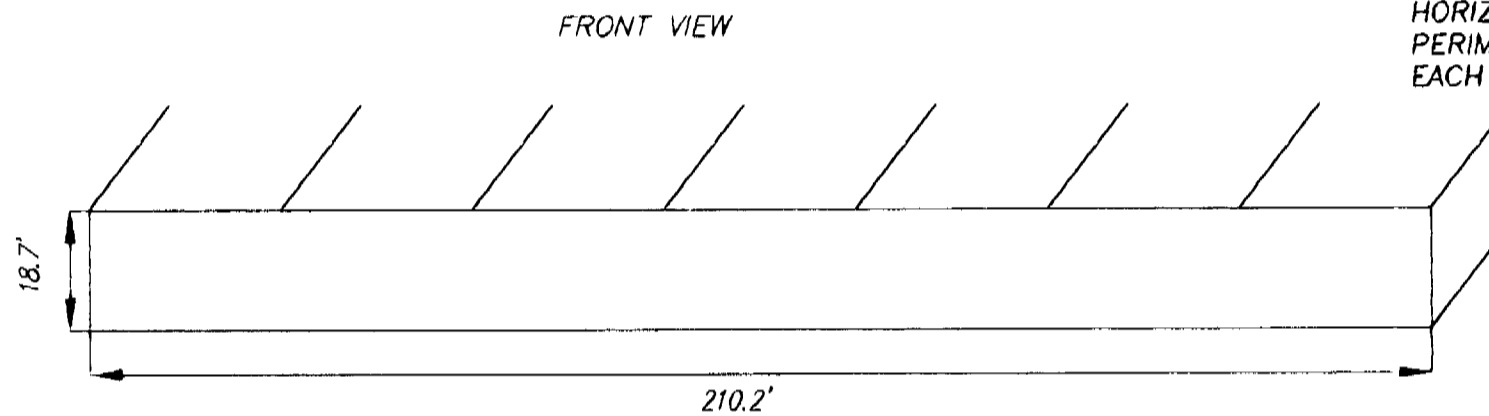
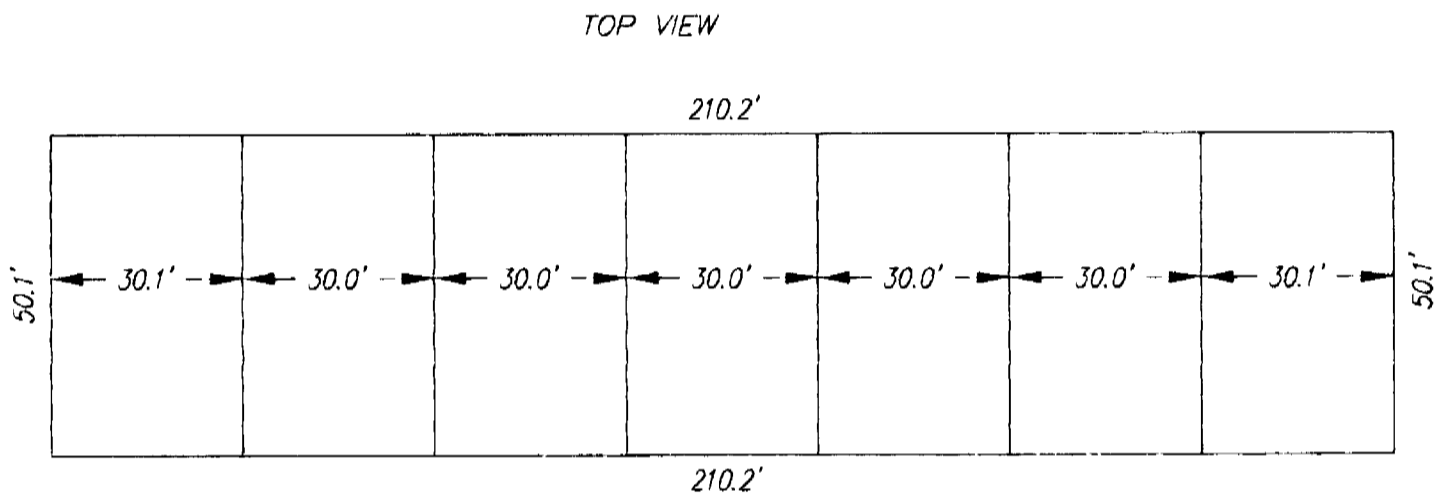

**LIMITED COMMON AREA**  
ONE-STORY GARAGE  
G1 THRU G4

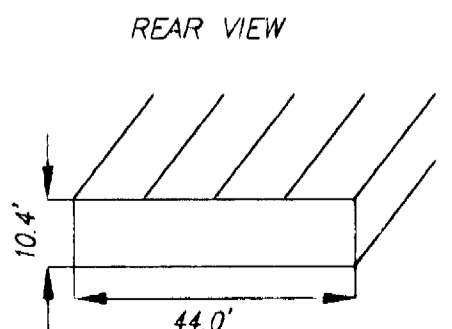
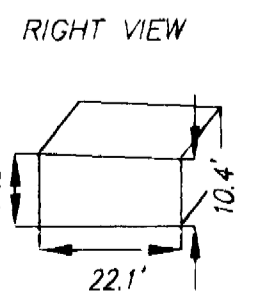
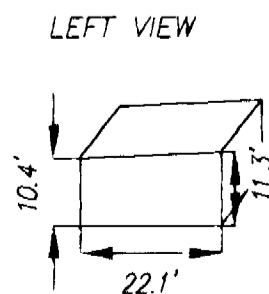
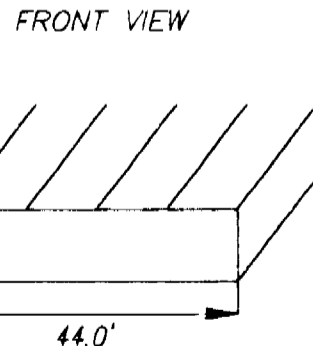
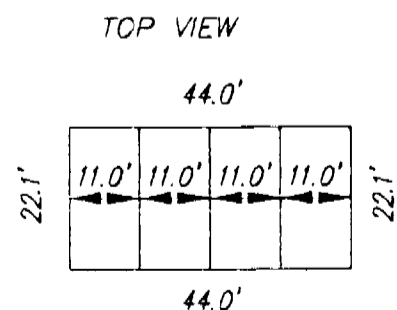

2 Large/Small Plat(s) Recorded herewith as # 050004203

**PLAT OF HANKINS BUSINESS CENTER**

A CONDOMINIUM  
JSRS ASSOCIATES L.L.C., A VIRGINIA LIMITED LIABILITY COMPANY  
JAMES CITY COUNTY, VIRGINIA

DATE: 11/29/04 SHEET 2 OF 2 SCALE: NA

PROJECT NO: 04-745 DRAWN BY: BSH

**THOMAS LAND SURVEYING, P.C.**

SURVEYING-GPS-MAPPING  
11830-A CANON BOULEVARD  
NEWPORT NEWS, VIRGINIA 23606  
(757) 873-2770

**NOTES:**

FINISH FLOOR ELEVATIONS: (PER APPROVED DEVELOPMENT PLAN)  
BUILDING A, UNITS A-1 THRU A-4 FINISH FLOOR ELEVATION= 106.00  
BUILDING B, UNITS B-1 THRU B-7 FINISH FLOOR ELEVATION= 105.75  
BUILDING C, UNITS C-1 THRU C-2 FINISH FLOOR ELEVATION= 104.75

DIMENSIONS SHOWN HEREON ARE APPROXIMATE AND ARE GRAPHIC REPRESENTATION ONLY. DERIVED FROM BUILDING PLANS PROVIDED. EACH INDIVIDUAL UNIT MAY VARY. THE HORIZONTAL AND VERTICAL BOUNDARIES ARE AS FOLLOWS:

VERTICAL BOUNDARIES ARE THE INTERIOR FACES OF THE PLYWOOD OR OTHER ROOF SHEATHING.

HORIZONTAL BOUNDARIES ARE THE UNFINISHED SURFACES OF PERIMETER WALLS AND THE MIDDLE OF EXISTING WALLS BETWEEN EACH UNIT.

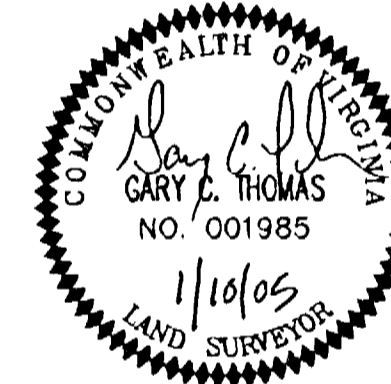

City of Williamsburg & County of James City  
Circuit Court: This PLAT was recorded on 1 March 2005  
at 10:21 AM/PM PG 1  
DOCUMENT # 050004203  
BETSY B. WOOLRIDGE, CLERK  
Betsy B. Woolridge Clerk

**STATE OF VIRGINIA**  
**JAMES CITY COUNTY**

IN THE CLERK'S OFFICE OF THE CIRCUIT COURT FOR THE JAMES CITY COUNTY, VIRGINIA, THIS MAP WAS PRESENTED AND ADMITTED TO RECORD AS THE LAW DIRECTS THIS 1<sup>ST</sup> DAY OF March, 2005 AT 10:21 AM/PM.

INSTRUMENT # 050004203  
TESTES: Betsy B. Woolridge  
CLERK  
TESTES: Claudia J. H. [Signature]  
DEPUTY CLERK