

88 page 26

#02.0025833

BUILDING DATA :
 OCCUPANCY : A3
 CONSTRUCTION TYPE : 5B
 AREA : 289 SQUARE FEET

DESIGN LOADS:
 ROOF LIVE LOAD: 20PSF
 FLOOR LOAD: 100 PSF
 WIND LOAD: 80 MPH
 SNOW LOAD: 20PSF
 SEISMIC LOAD: GROUP 1, Av=0.05

GENERAL NOTES

1. ALL CONSTRUCTION SHALL COMPLY WITH THE VIRGINIA UNIFORM STATEWIDE BUILDING CODE, 1997 EDITION.
2. ALL FRAMING AND LUMBER SHALL BE NO. 2 SOUTHERN YELLOW PINE, PRESERVATIVE TREATED 0.4 RETENTION, AS HEREIN SPECIFIED IN ACCORDANCE WITH MANUFACTURER'S RECOMMENDATIONS.
3. BOLTS SHALL CONFORM TO ASTM A307, PROVIDE GALVANIZED PLATE WASHERS UNDER NUT AND HEAD.
4. ALL NAILS, BOLTS, NUTS OR OTHER METAL HARDWARE SHALL BE HOT-DIPPED GALVANIZED.

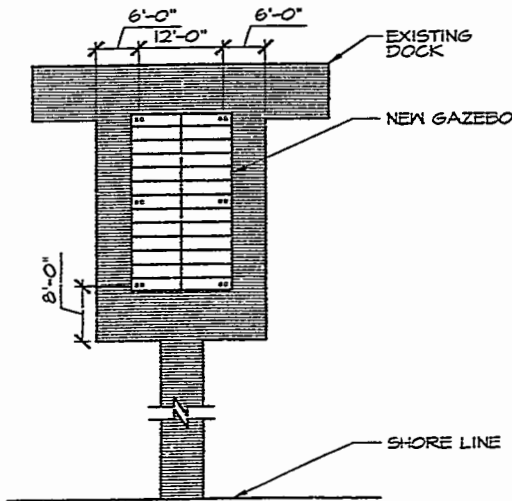

1 DOCK PLAN
 1/16"=1'-0"

EXHIBIT A

City of Williamsburg & County of James City
 Circuit Court: This PLAT was recorded on

4 Nov 2002
 at 8:47 AM PB 88 PG 26 of 28
 DOCUMENT # 02.0025833

BETSY B. WOOLRIDGE, CLERK
 Betsy B. Woolridge, Temp. Clerk

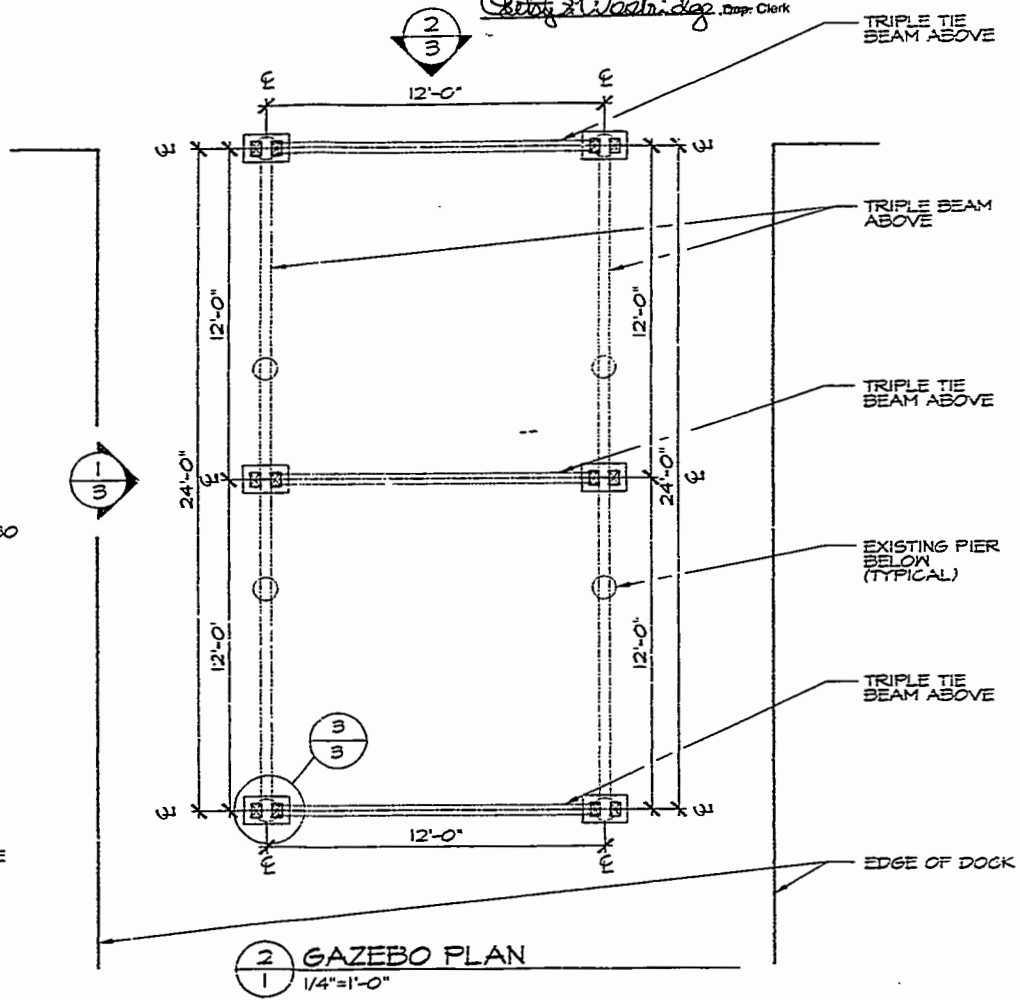

2 GAZEBO PLAN
 1/4"=1'-0"

**Guettnsey
 Tingle
 Architects**

Mill Pond Park Gazebo
 Stonehouse

James City County, Virginia

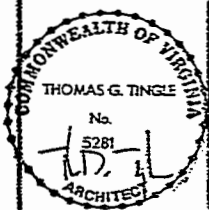

Date	10-18-01
Drawn	PLH
Checked	TST
Project	201055