

PLAN VIEW

Pump Tank

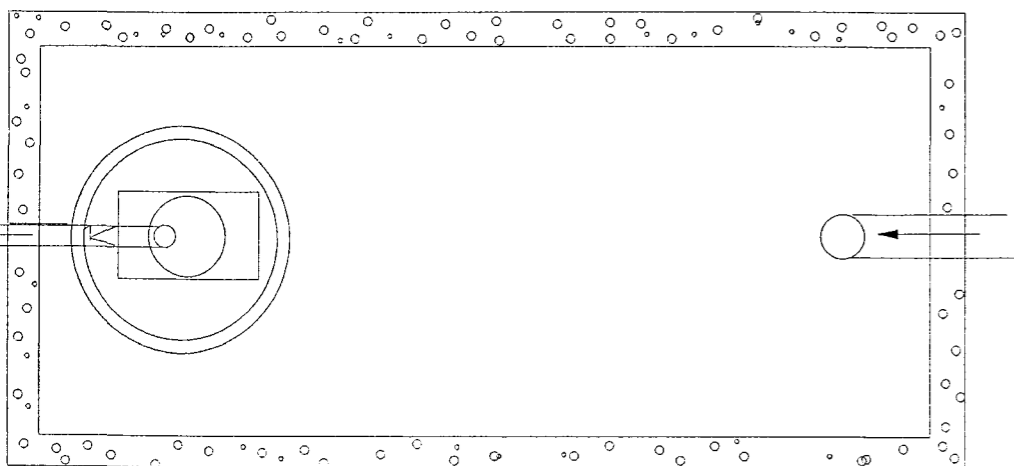

SEPTIC TANK

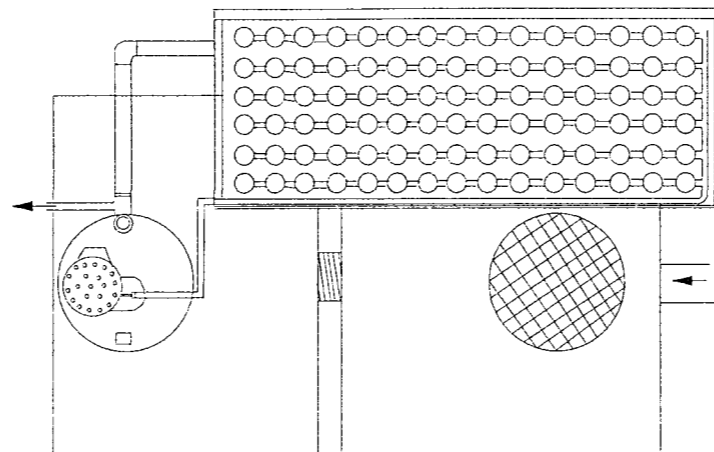
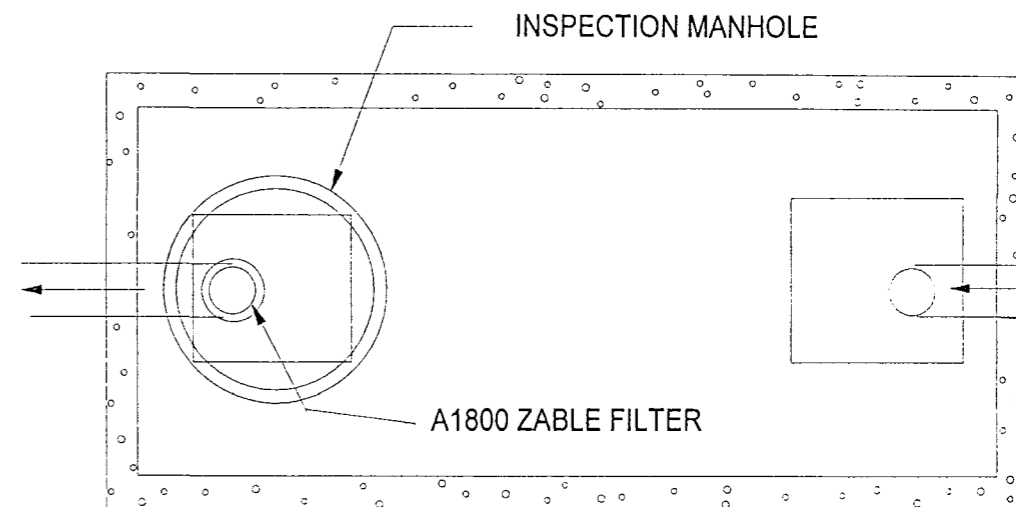

Advan Tex AX-20

DRAINFIELD TRENCH USE INFILTRATORS

ORIGINAL GROUND LEVEL

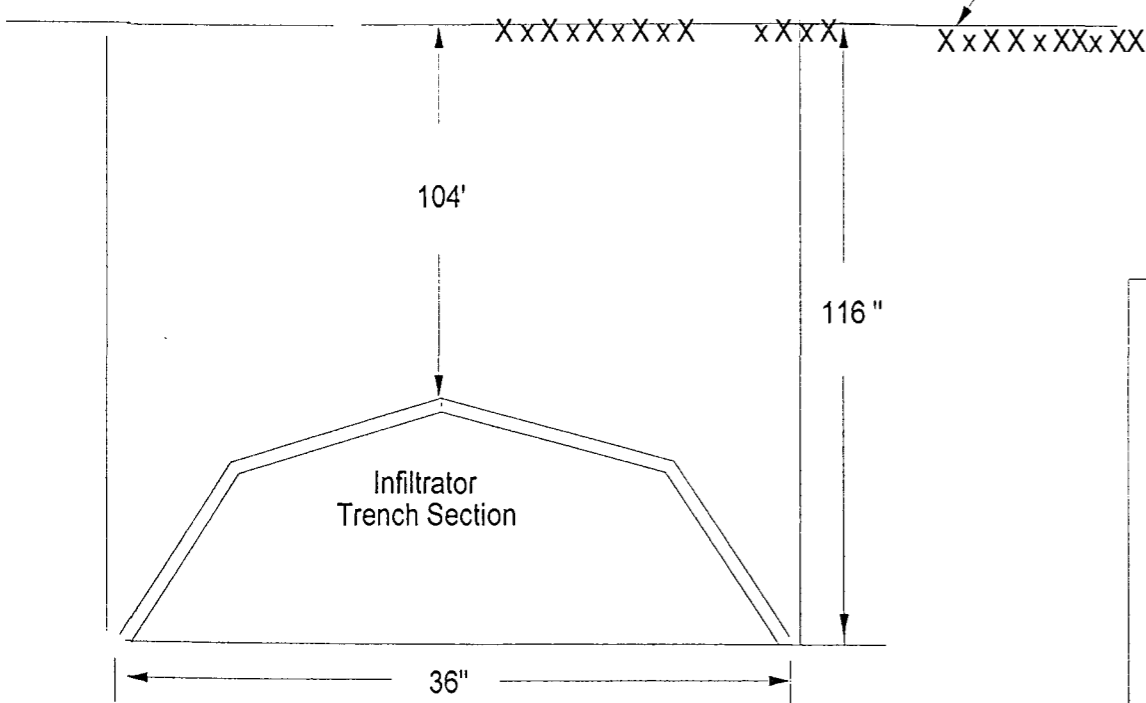

City of Williamsburg & County of James City
Circuit Court: This PLAT was recorded on

10 July 2003

at 11:32 AM/PM. PB 90 PG 81-84

DOCUMENT # 030020508

BETSY B. WOOLRIDGE, CLERK

Betsy B. Woolridge Clerk

PROPOSED SEWAGE DISPOSAL SYSTEM

FOR

OAKWOOD HOMES

TAX MAP # 21-4 (2-15)

COUNTY— JAMES CITY COUNTY

SCALE- N.T.S.

DATE- MAY 15, 2003

PAGE 2 OF 4

Phone- 804-725-7348

DRAWING NUMBER 03-W61

prepared by:

William J. Meagher, C.P.S.S.
Post Office Box 950
Main Street
Mathews, Virginia 23109

under the direction of:

John D. Williams, P.E.
4307 Coventry Road
Richmond, Virginia 23221

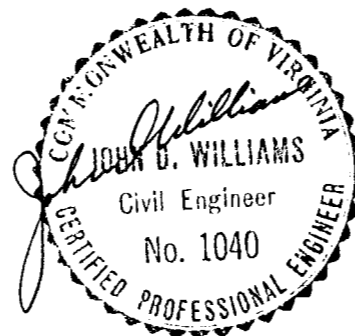

90 PAGE 82